

DB D HCE EH EFB: C

The Solution

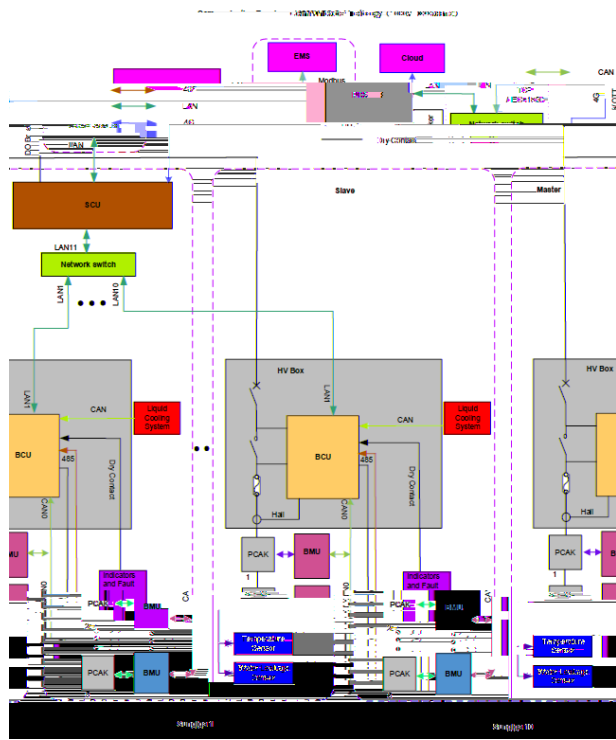

ECC D ED FEE

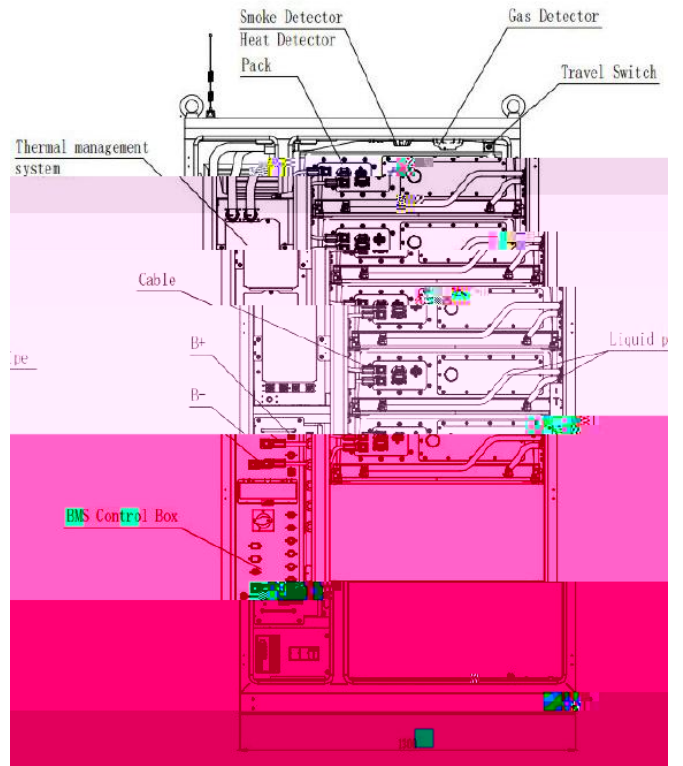

D D B E

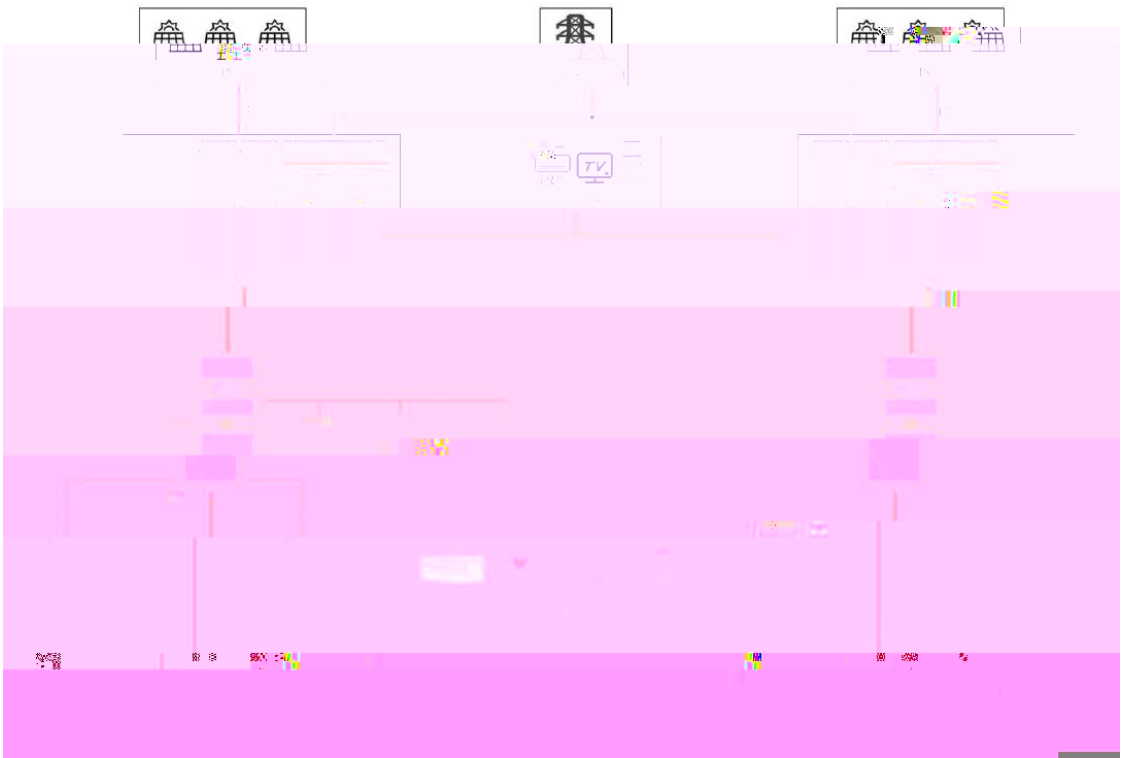

H F

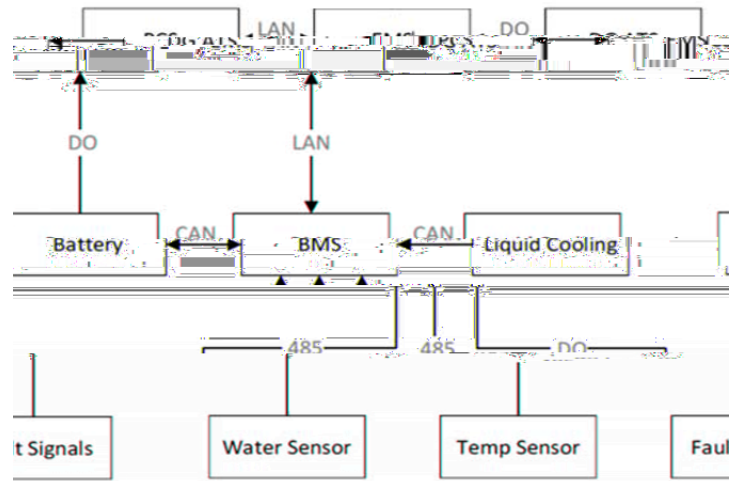

ESS D EEE

Operation Logic

①

①

②

②

③

③

Monitoring Systems

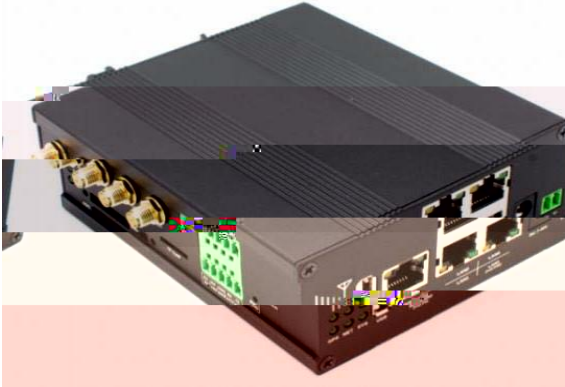
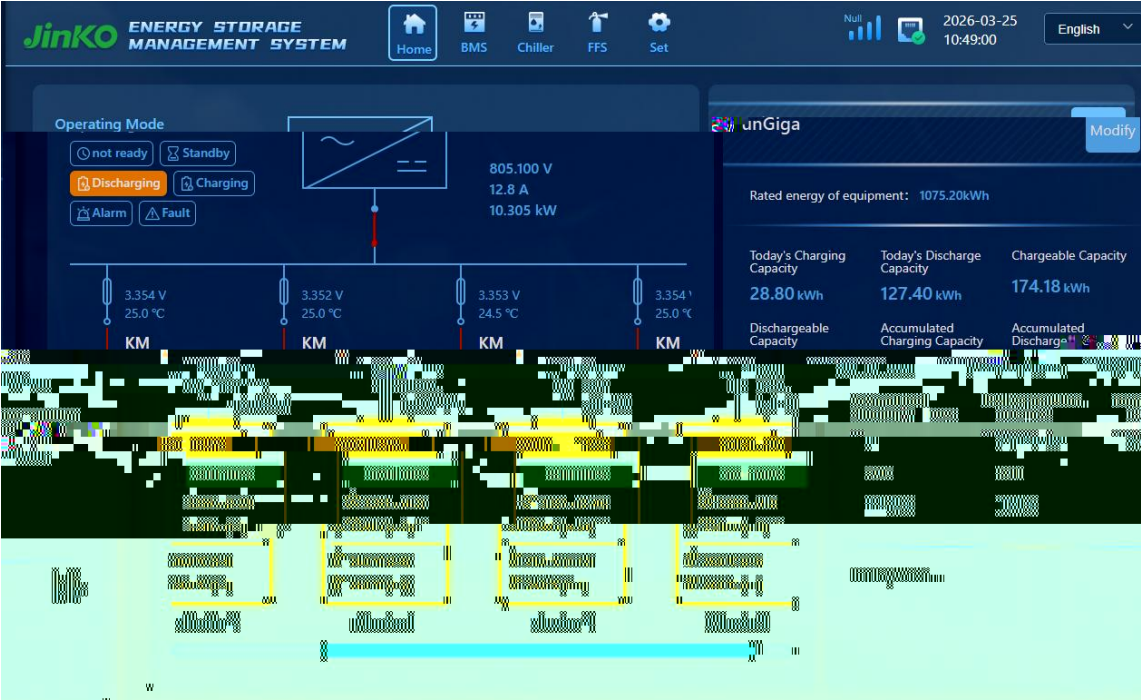

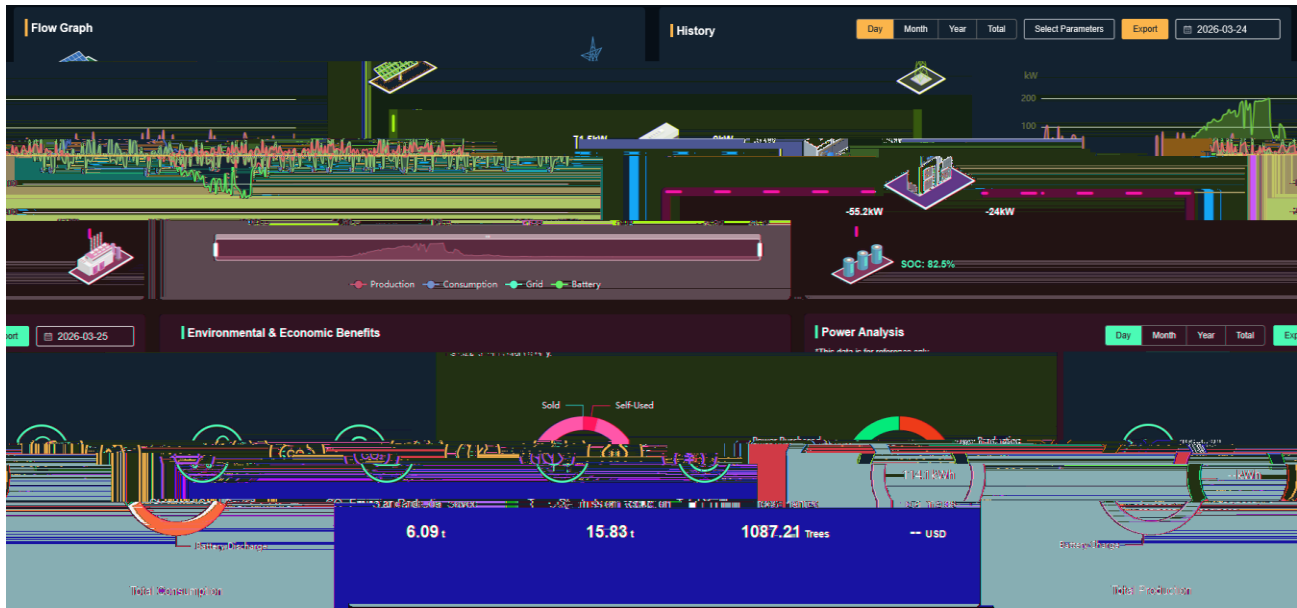

* The report serves as a general overview and is subject to updates by Jinko ESS. Jinko ESS reserves the right to modify the content and holds the final authority in its interpretation.



Zhejiang Jinko Energy Storage Co.,Ltd.

No.8, Xiangxin, Road, Huangwan Town,
Haining City, Jiaxing City, Zhejiang
Province, China

Case Study

Jinko ESS Solution of Micro-grid DC-coupled System