



SunGiga

1MW/2.15MWh 锂电储能系统项目——刚果(金)马科罗微电网

Storage System

DC-coupled Energy

DG

1MWp
ESS

1MW/2.15MWh

JinKO ESS

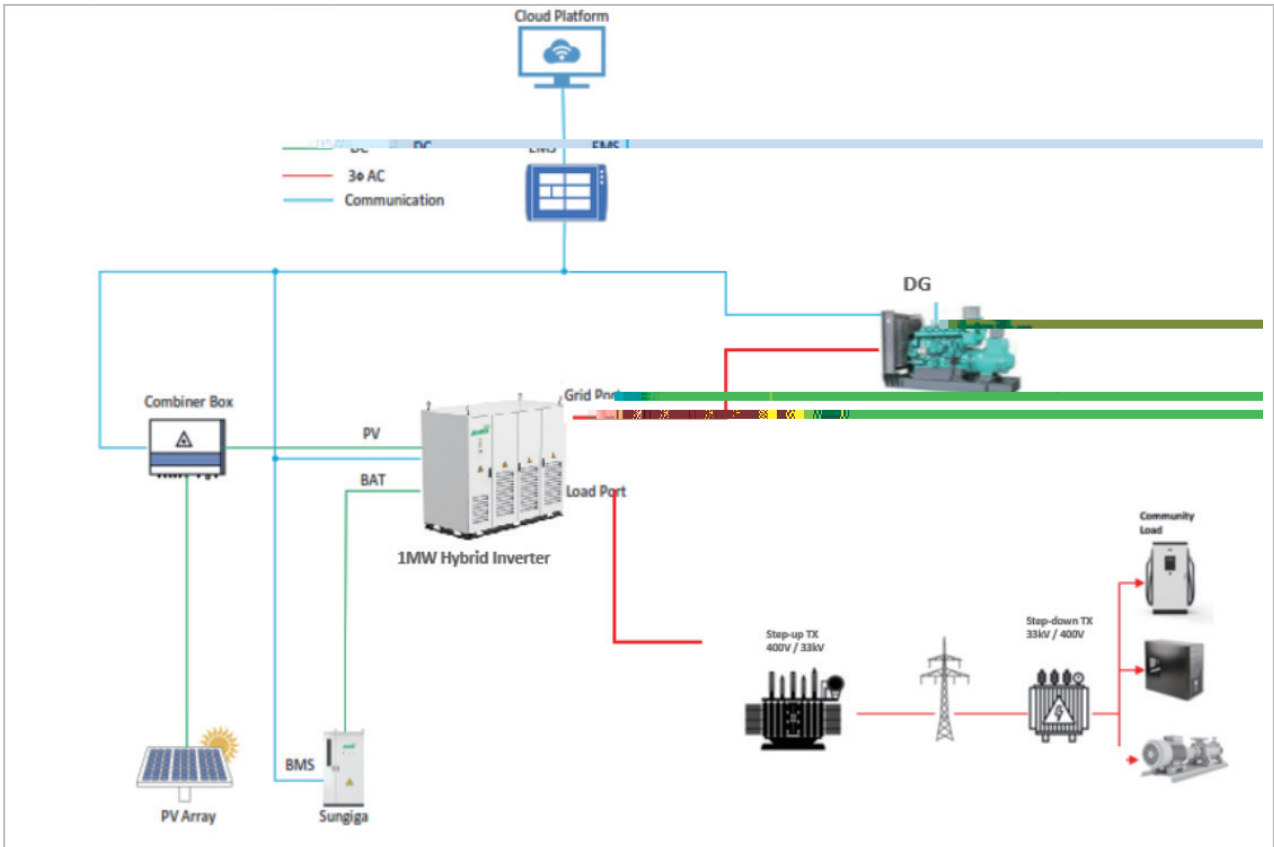

1.

BMS

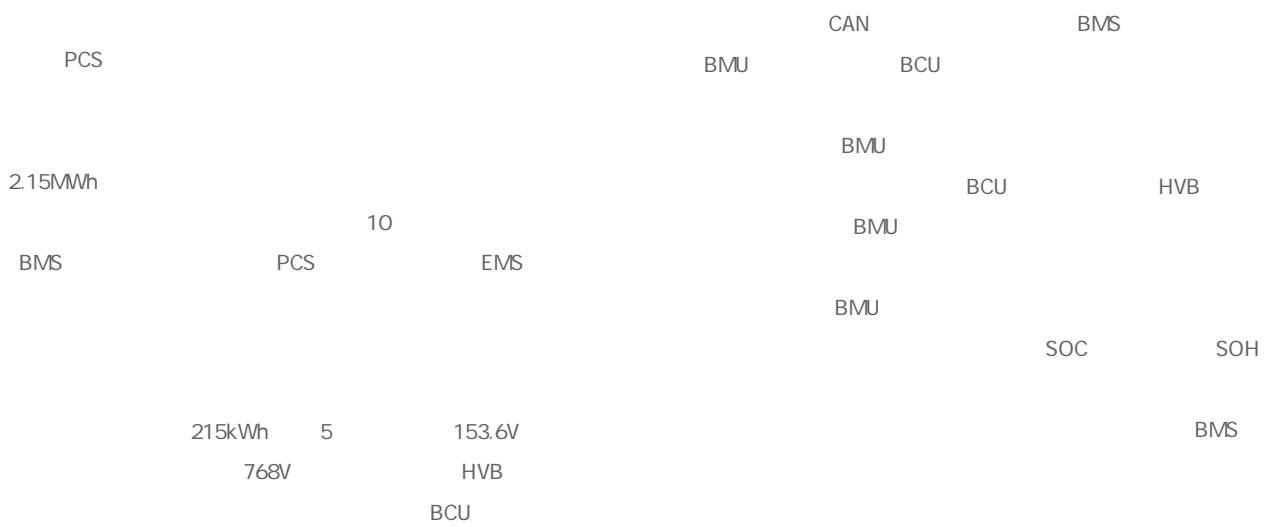

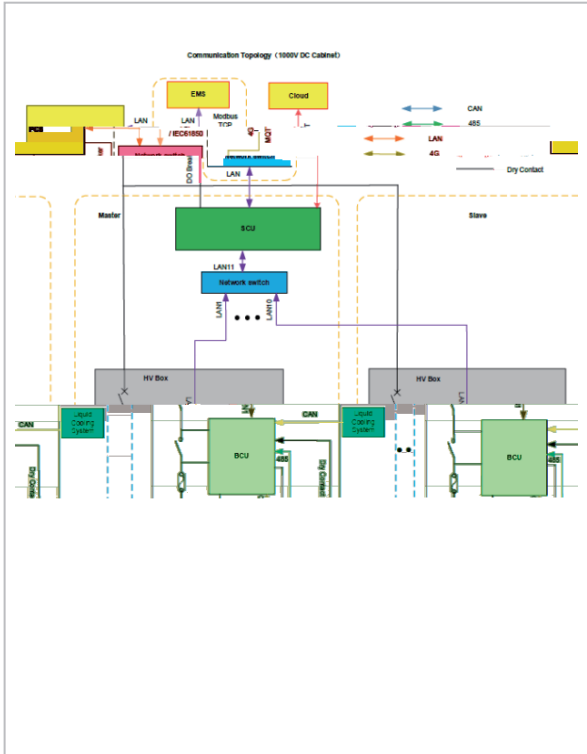

2 BMS

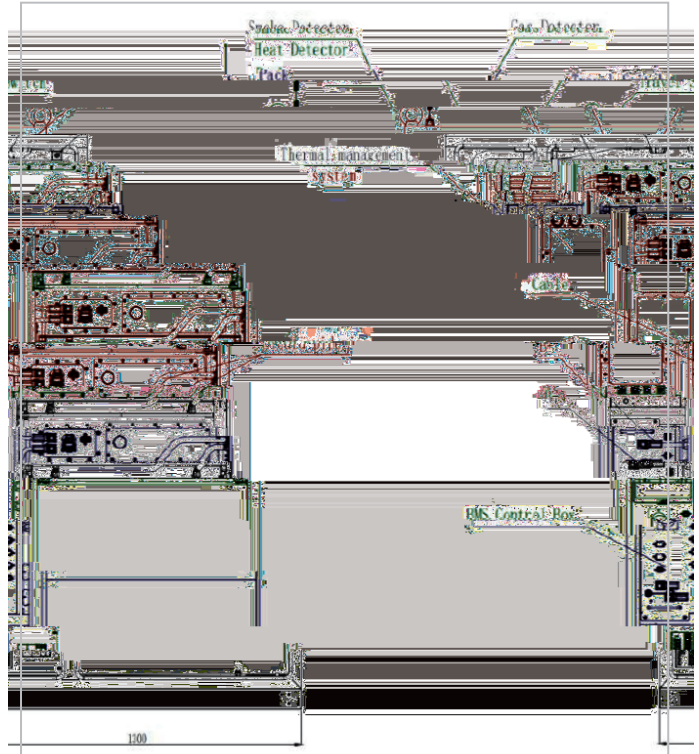

3 SunGiga

FSS

ESS

FSS

FSS

PCS

500kW

1MW

PCS

PCS

20

PCS

DC-BUS

- DC-DC

DC-DC

DC-DC

/

DC-AC

DC-AC

DC-AC

DC-AC

PCS

110%

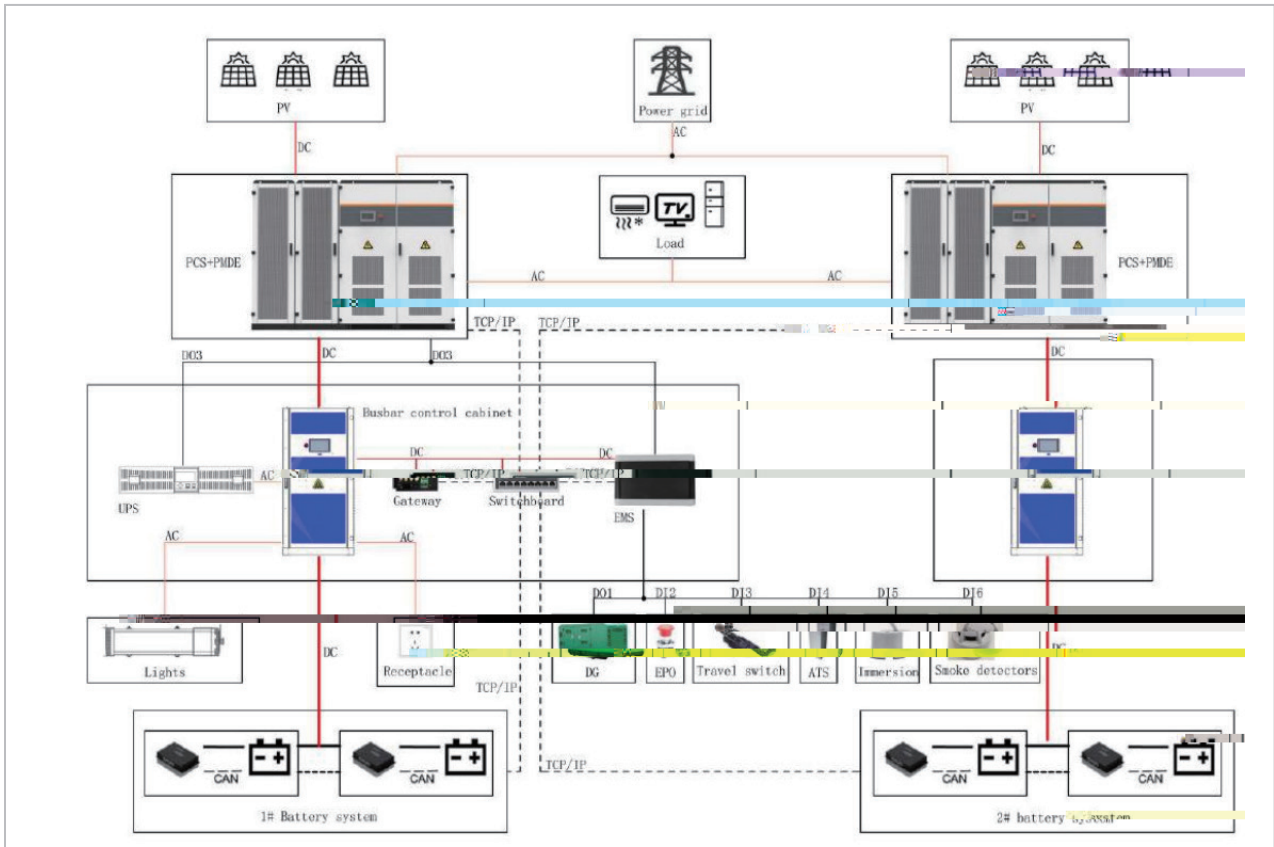

4. PCS

EMS

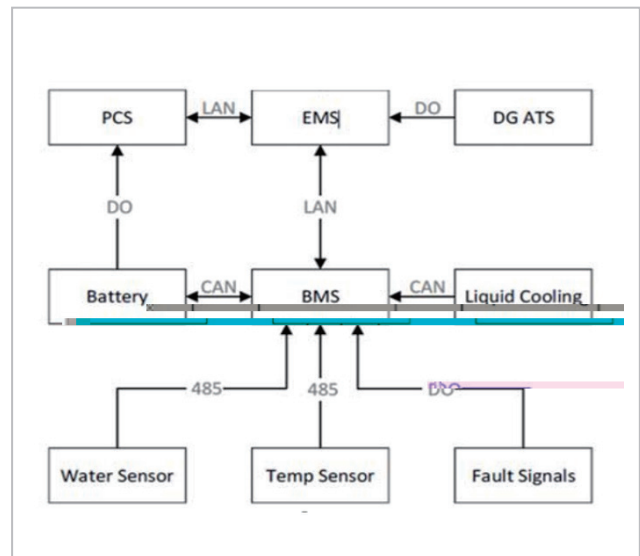
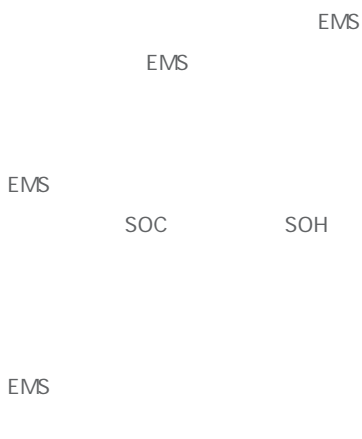

5. EMS

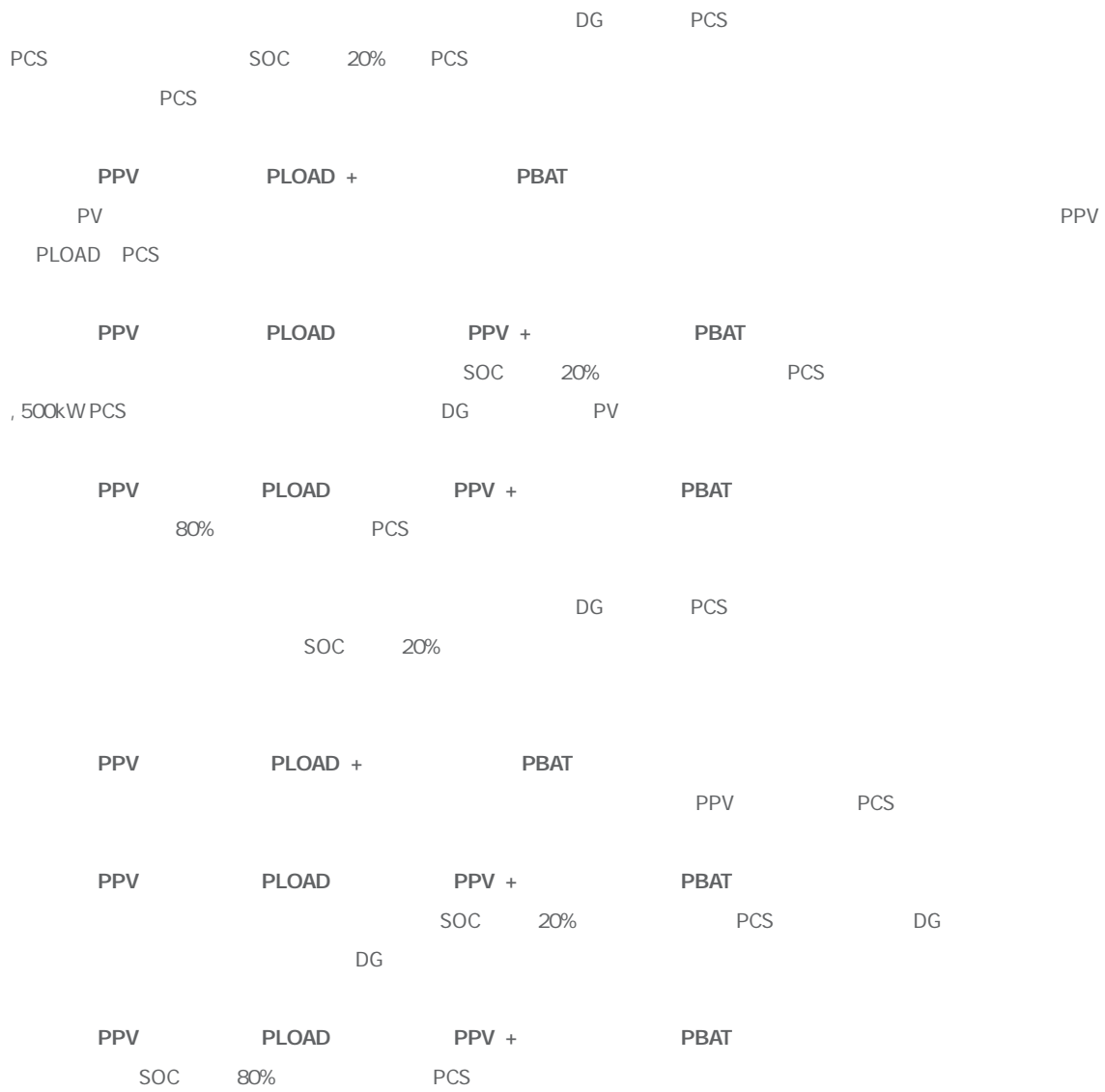

BESS



SCU

		Site Control Unit, SCU	5	
FSS	BMU	BCU		SunGiga
SCU			VPN	

EMS



7.

*



+86 400 860 8878