



Jinko ESS Liquid Cooling Solution of Micro-grid AC- coupled System

250kW/645kWh Li-ion BESS Project in Lebanon

Case Study

Project Overview

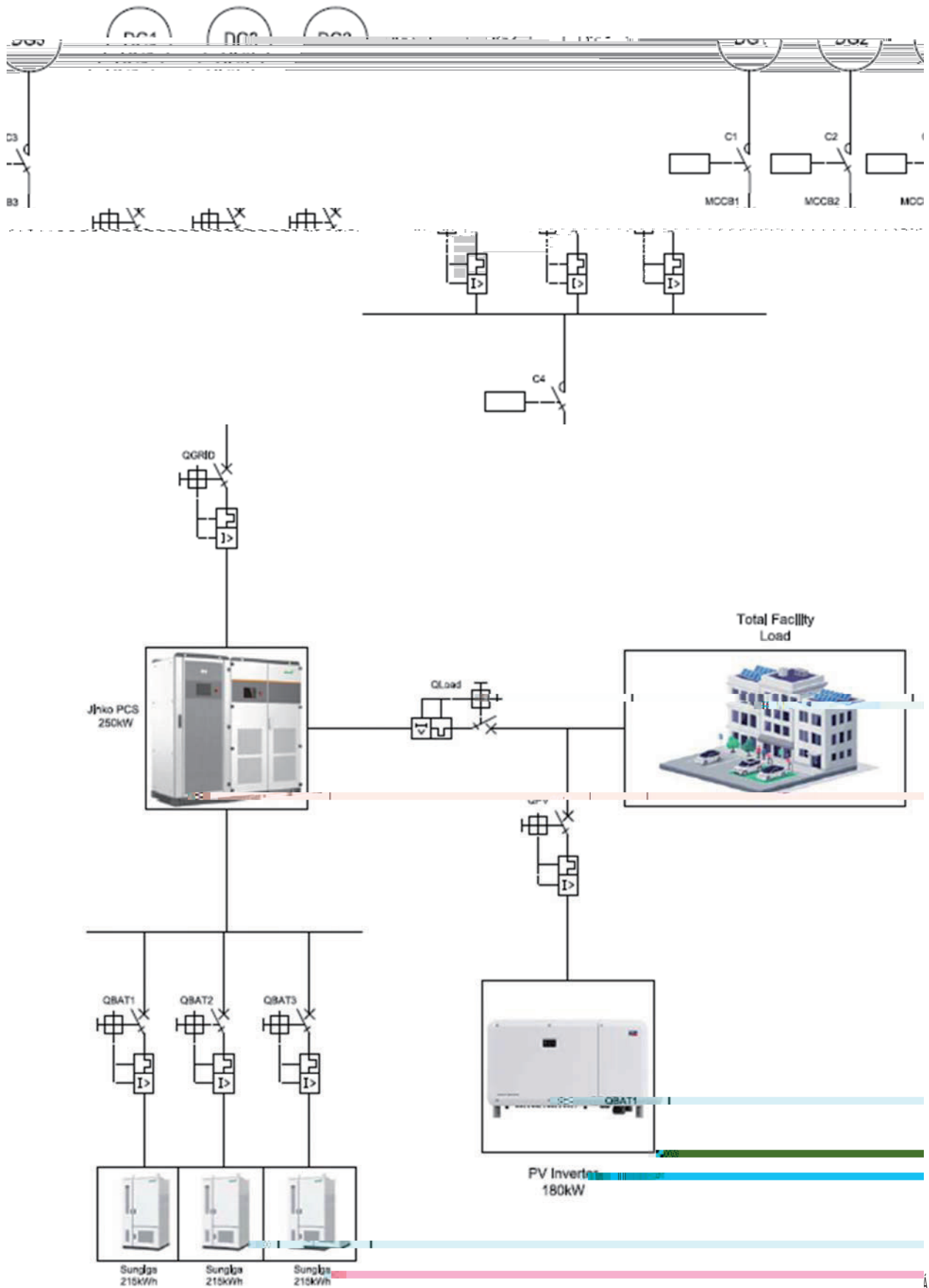

Fig. 1 Single Line Diagram of Micro-grid AC-Coupled System

a g f a

Fig. 2 BMS Communication Topology

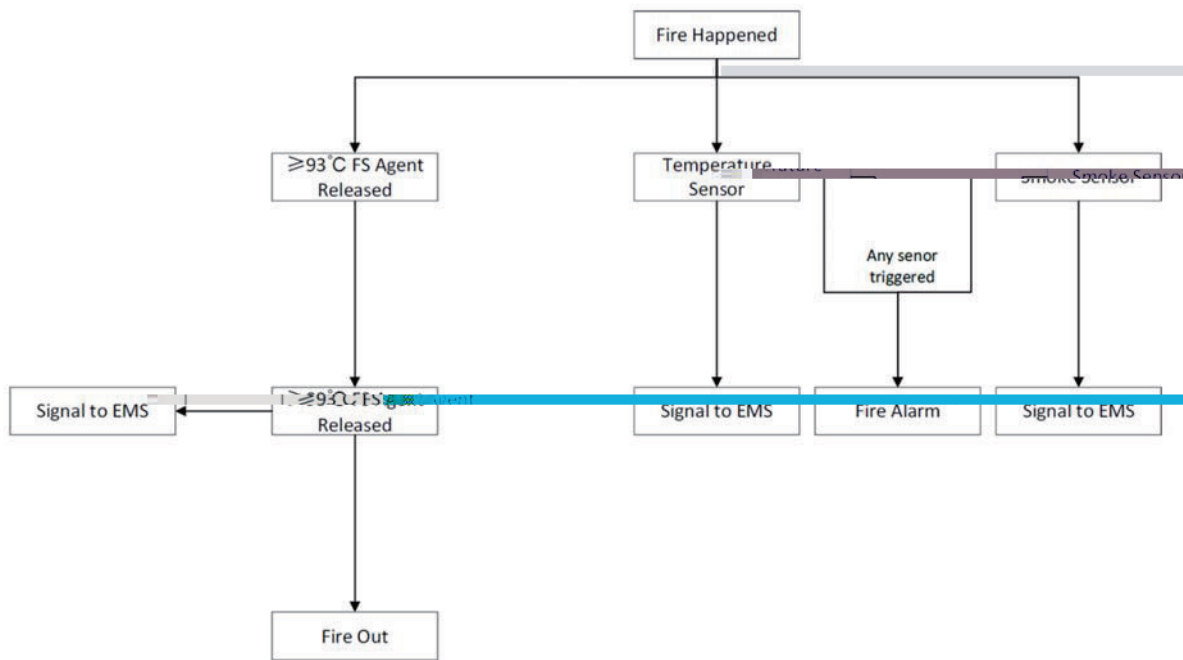

Fig. 3 FSS Workflow



Fig. 4: PCS Single Line Diagram

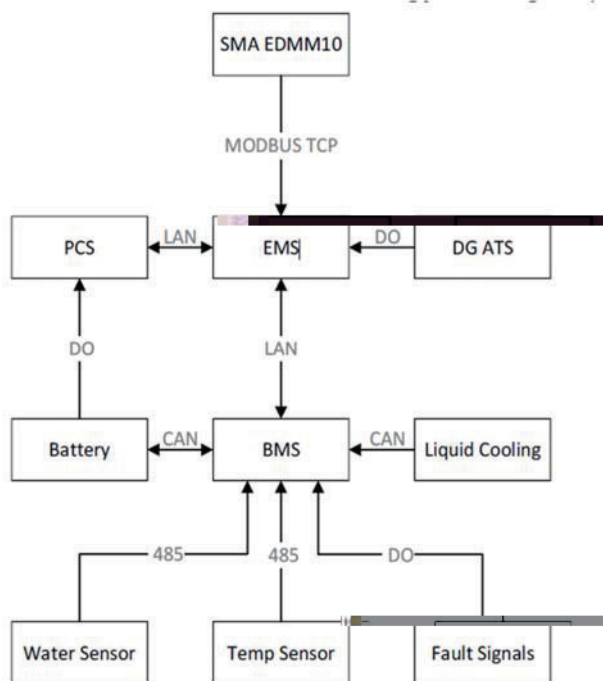

Fig. 5: EMS Communication Topology

A dSf a a

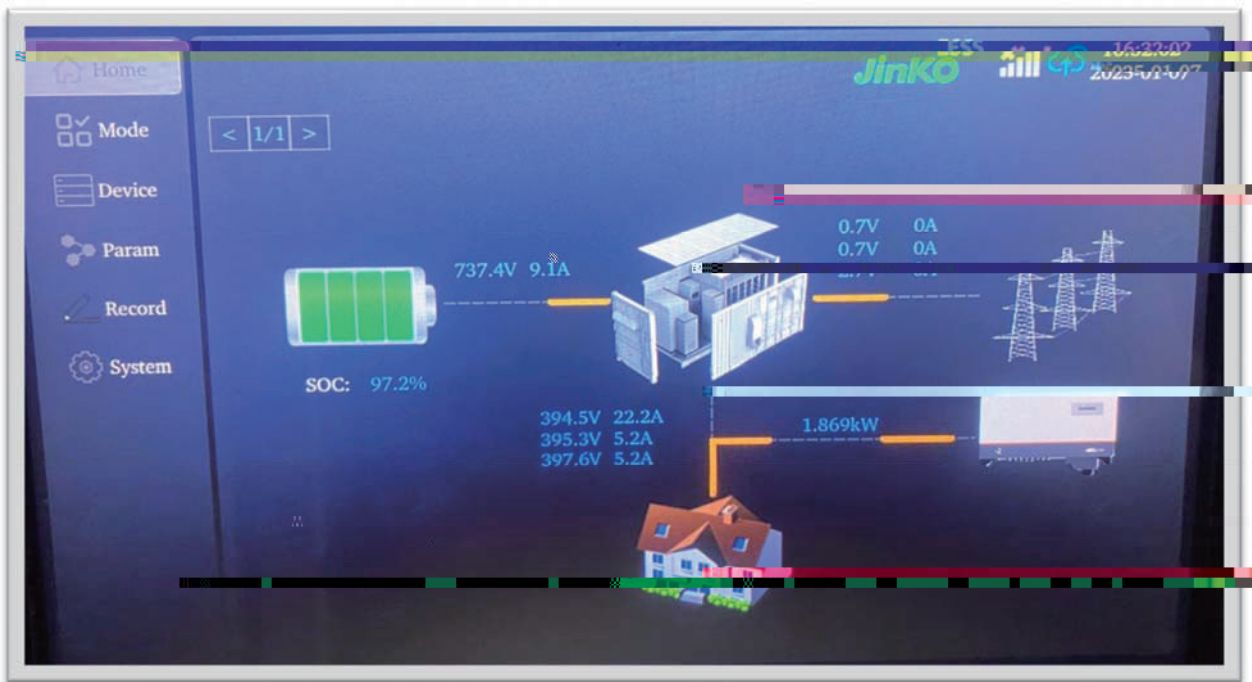

Fig. 5: EMS HMI Display

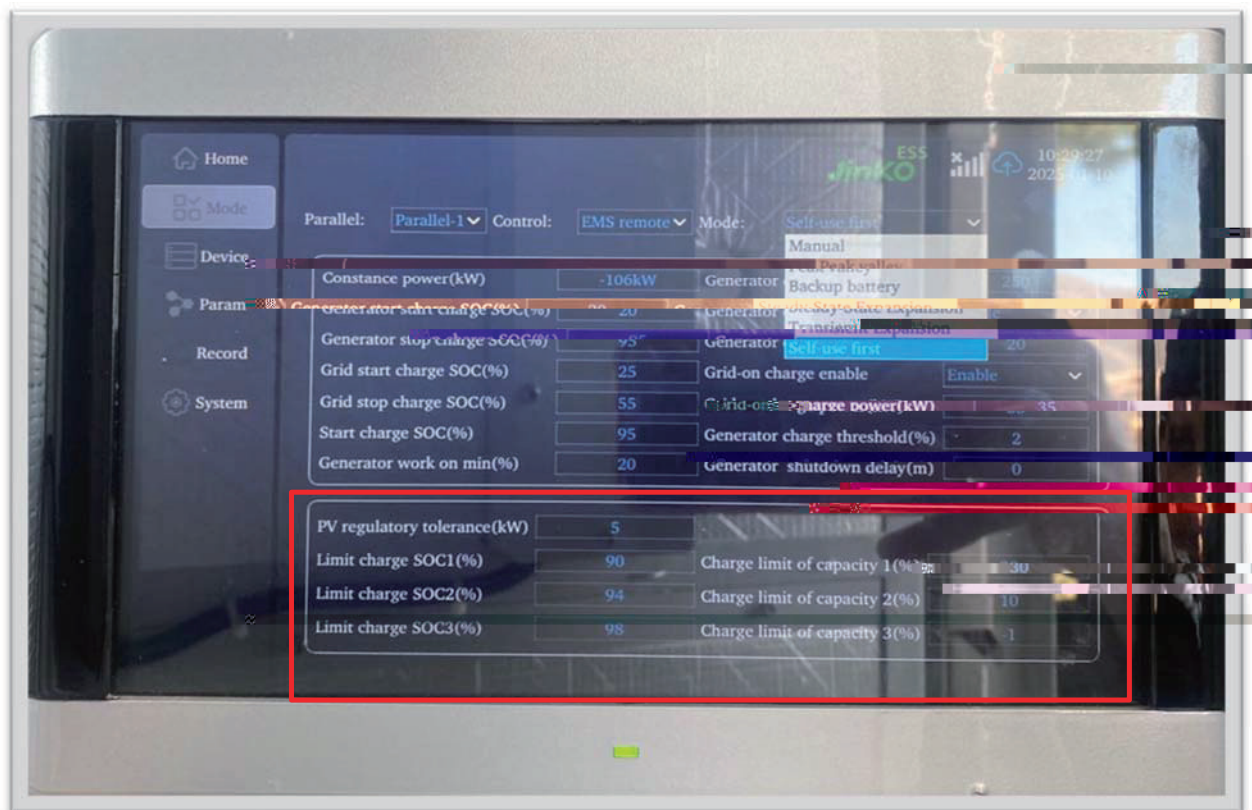

Fig. 6: EMS PV Inverters Power Limit Thresholds.

a fad kefe

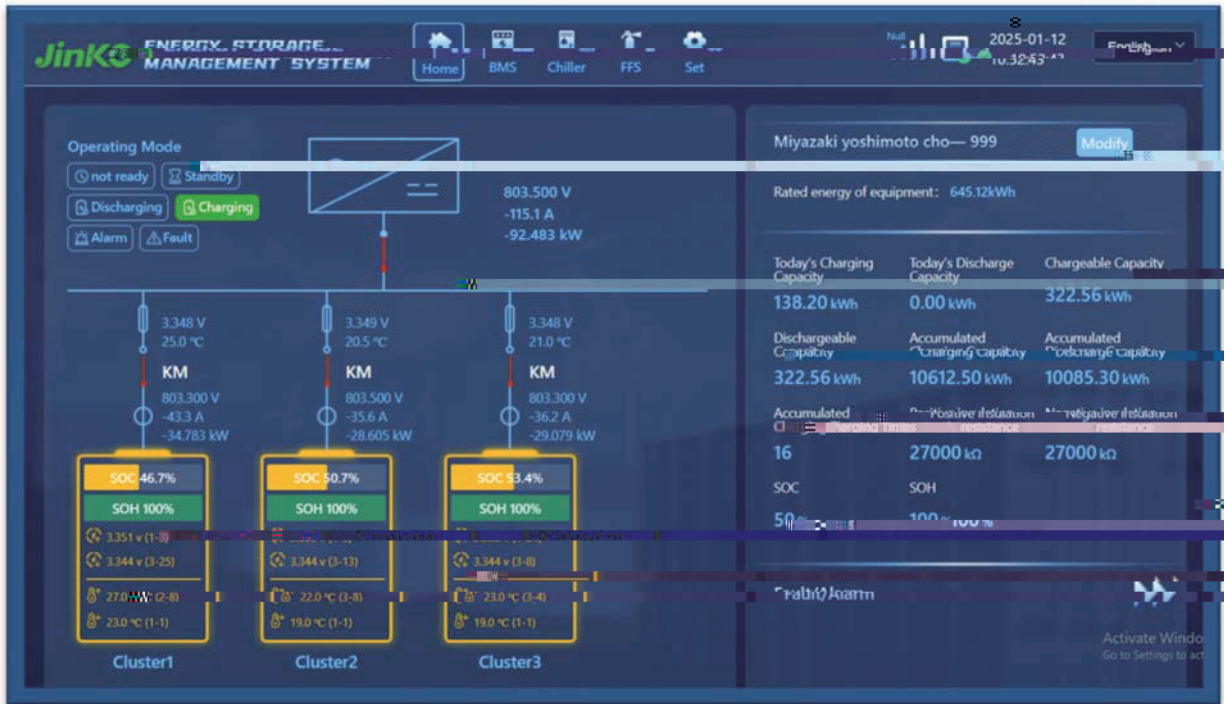

Fig. 6: SCU Cloud Monitoring Display



Fig. 7: System IoT Router

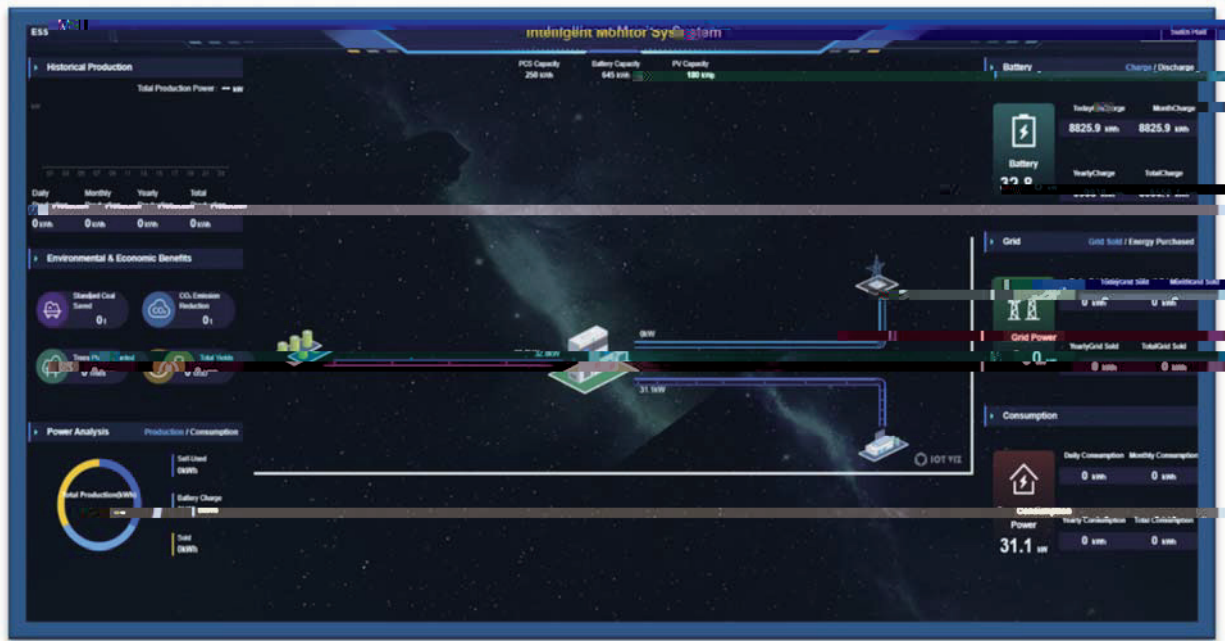

Fig. 8: EMS Cloud Monitoring Platform

6 Sfs Ske e

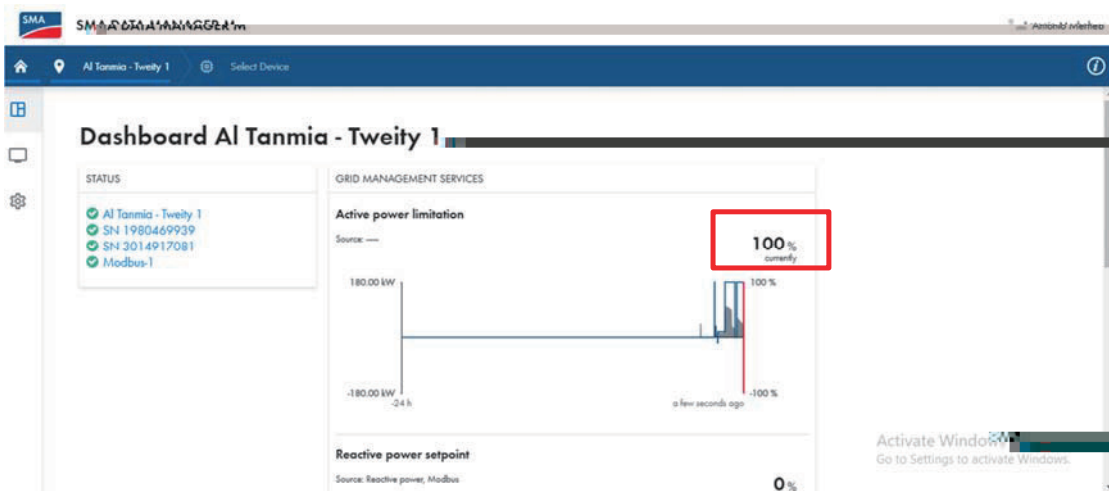

Fig. 9: SMA Monitoring platform showing 100% setpoint received from EMS

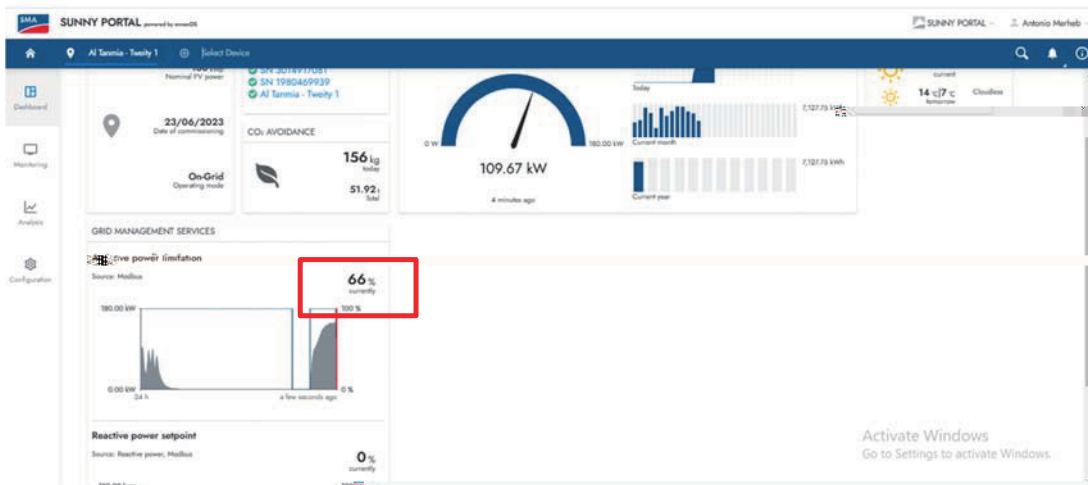

Fig. 10: SMA Monitoring platform showing 66% setpoint received from EMS

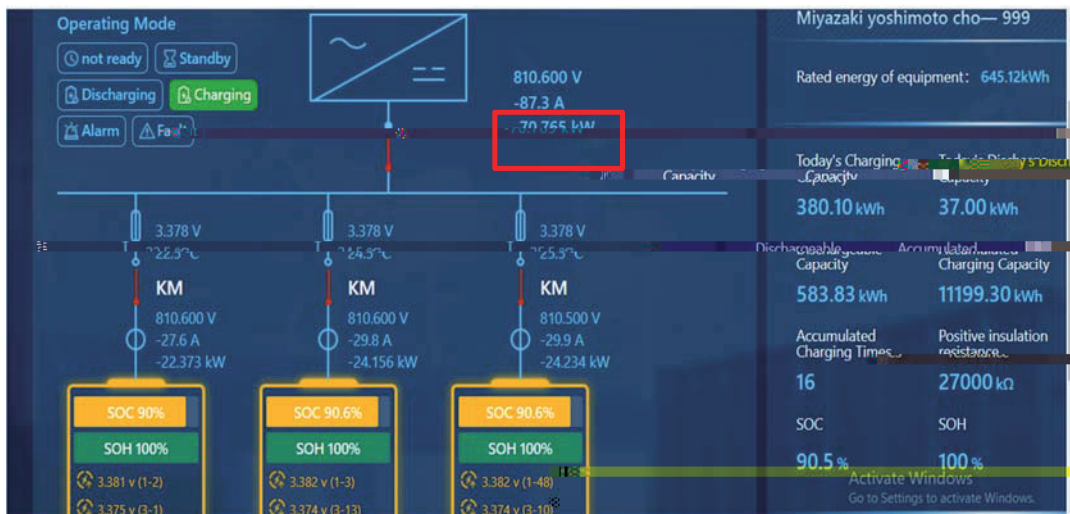

Fig. 11: SCU Monitoring showing charging power limit at 90% SOC



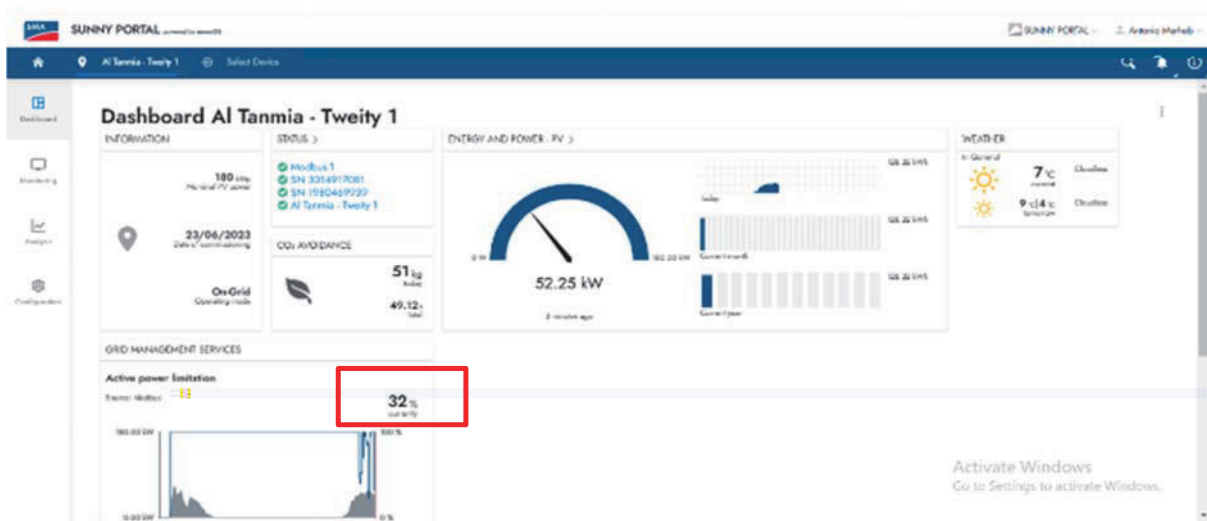

Fig. 12: SMA Monitoring platform showing 32% setpoint received from EMS

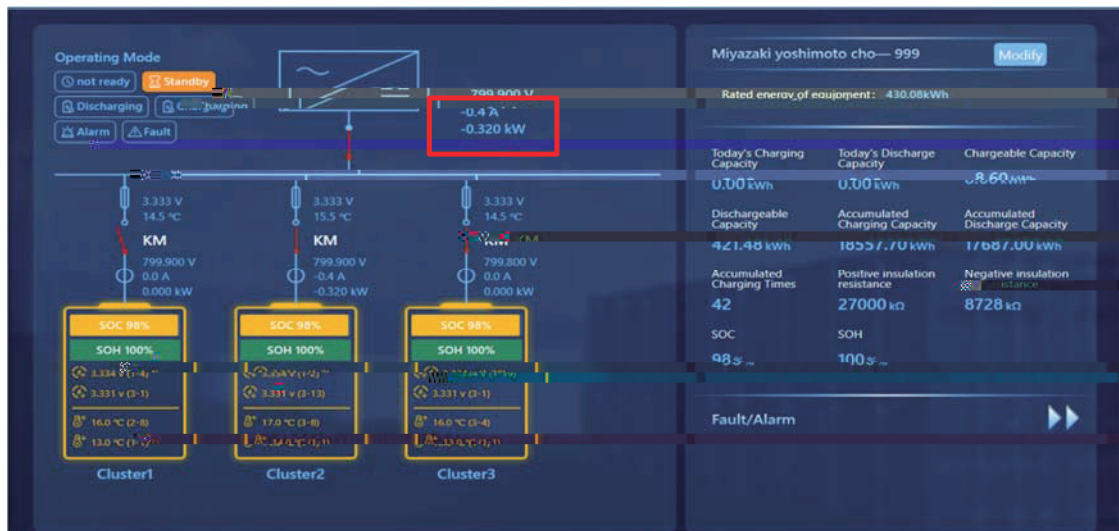

Fig. 14: SCU Monitoring showing charging power limit at 98% SOC

5 a ge a



EIV@^i^ [tol^c^*kæ*æi*^)^iæj{ç^iç^, kæ) äi*~äi^&ok[i^] äæ^*lä^iRi) \ (iÖÜEIRi) \ (iÖÜÜi^*^iç^*k@^iäi*^ok[i^ { [äi^*k@^i&{ }^)^okæ) äi@ [jâ*^k@^i-äi)æjka~o@ [iäc^iä)äc*äi)ç^i!]^ææd[]Eä

Á

Á



a a Sd5a f
 b [ÉFÉiSæ}^iF i î íÉÜ@^}&@æ} *iÜ [æäÉTä) @æ} *Á
 Öi=c:i&cÉiÜ@æ} * @æäÉiÖiä) æÁ
 v^iÉiîiäiæiîiæiîiîiä

Á

Ôæ*^iÜc~ä^Á
 a 7 a g f a a çä d 5 ag
 kef

Á